



Versetta Stone™

The beauty of stone, perfect by design.™

MANUFACTURER'S INSTALLATION INSTRUCTIONS

Building code requirements vary and it is suggested that you check with local authorities to determine requirements for your area. Carefully read all installation instructions before proceeding with installation. Observe all safety precautions.

The Owens Corning Masonry Products, LLC Versetta Stone™ masonry siding product* is designed for application over wood framing, spaced 16 inches on center and covered by a code approved, nailable sheathing product. Currently, Owens Corning requires a minimum 7/16" OSB or 1/2" plywood sheathing beneath the Versetta Stone™ product. Wall framing should be designed to limit out-of-plane wall deflection to a minimum of L/240. At a minimum, the building's corners should be sheathed to meet local building code requirements and to mitigate the effects of wall racking. Roofing and interior wallboard should be installed prior to starting installation. Walls are to be plumb within 1/4" per 10 lineal feet. Expansion joints for the Versetta Stone™ product should be provided as specified by the registered design professional. This product has not been tested nor is intended for applications over 30' in height. Provide a means for drainage and ventilation at all horizontal terminations. This is typically achieved by using starter strip and J channel in conjunction with flashing products and generally accepted practices.

HANDLING AND STORAGE

The product should be transported and stored in the original shipping package until ready to use. When sub packs are removed, transport and store with top (nailing flange) up. See Figure 1.

ESTIMATING MATERIALS

1. Determine the wall area to be covered. Do this by multiplying the wall width (in feet) by the wall height (in feet).
2. Subtract the area of windows, doors or any other area that will not be covered. This is your net wall area.
3. If corners are to be covered, measure the height of wall corner (in feet). Plan that each lineal foot of corner will provide 1 sq. ft. of wall area coverage. Therefore the wall corner height in feet is your corner coverage.
4. If Versetta Stone™ Trim Stone will be used, they will also contribute to coverage of wall area. To determine Versetta Stone™ Trim Stone coverage, calculate the lineal footage that will be used, in feet, multiply by 12 to convert to inches and then multiply by 8 to reach area in total square inches. Next, divide by 144 for Versetta

PRODUCT DIMENSIONS AND SPECIFICATIONS (SUBJECT TO NORMAL MANUFACTURING TOLERANCES)

FIGURE 1 - STORAGE

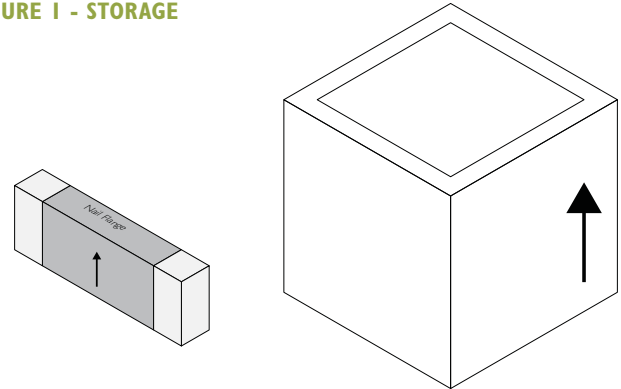

FIGURE 2 - STARTER STRIP



FIGURE 3 - J CHANNEL

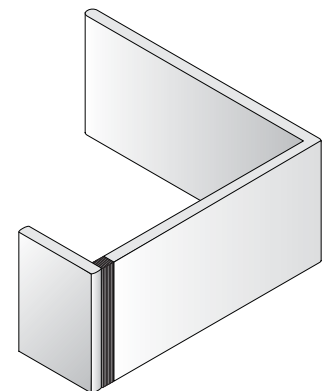
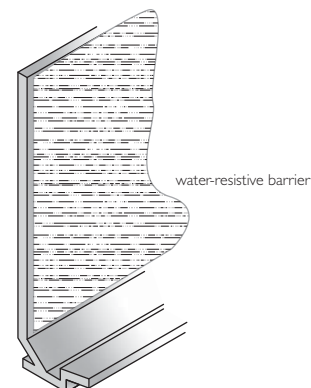

FIGURE 4



Stone™ Trim Stone coverage in square feet. Subtract this output from your total wall area requirements as you did with windows and doors, in step 2.

If you are using other accessories they will also account for some of the wall area coverage. We suggest you use these to help support your factor for scrap.

Formula:

Net Wall Area – Corner Coverage – Trim Stone Coverage = Flat Panel Area

Flat Panel Area / 2 = Number of flat panels required

Height of corner (in feet) x 12 / 8 = Number of corner panels required

A factor for scrap should be included, and it is suggested you start with 10%. As you become more familiar with the product you will be able to drive this requirement lower.

Fasteners

Each full flat panel requires a minimum of 4 fasteners. Each corner panel requires a minimum of 2 fasteners.

Starter Strip

Starter strip requirements are equal to base wall width measured in feet and rounded up to the nearest 10 foot increment. See Figure 2.

J Channel

J channel requirements are determined by measuring perimeter of window and door openings, trim material transitions, cladding transitions and any control joints. Consult the *Flashing and Construction Details* supplement document for assistance. See Figure 3.

Tools

Hammer, circular saw, hand grinder, table saw or wet saw with continuous diamond turbo blade, level, laser level (optional), chalk line, tape measure, pneumatic roofing nail gun (optional), tin snips, 5/16" rod or dowel (optional), brush, small screwdriver. Follow tool manufacturer's safety instructions.

Partial Panel and Accessory Adhesive

Each 10 fl. oz. cartridge will adhere approximately 4 partial panels. Likely areas where partial panels will be installed include; under windows, eave terminations, and at horizontal material transitions. Determine estimated length of these areas and divide by 3 and then by 4. This will provide an estimate number of 10 oz. tubes you may need. Recommended adhesive PL Premium Construction Adhesive.

Colored Sanded Caulk

A colored sanded caulk will be helpful to conceal any supplementary fasteners or odd material terminations.

Personal Protective Equipment

Safety glasses or goggles, a properly fitted NIOSH approved N-95 series disposable particulate filtering facepiece respirator (formerly referred to as "dust masks"), gloves, ear plugs or muffs, steel toe boots and hard hat.

DETERMINE AND MARK YOUR STARTING POINT

FIGURE 5 - FLAT PANEL

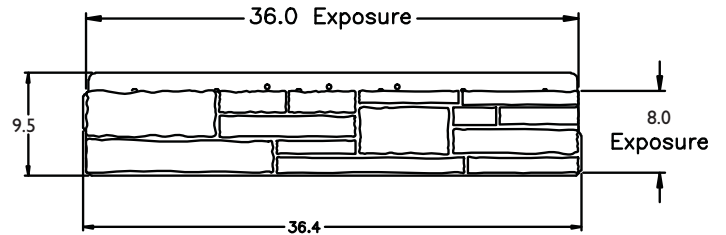

FIGURE 6 - LEFT CORNER PANEL

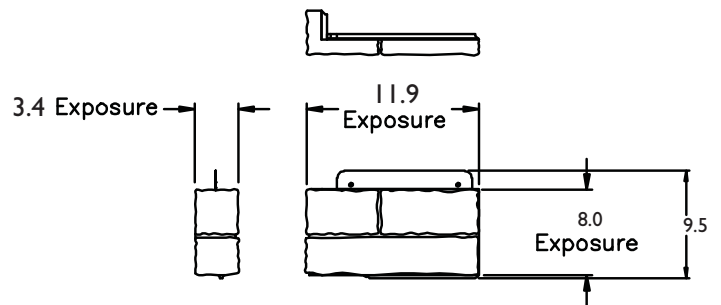

FIGURE 7 - RIGHT CORNER PANEL

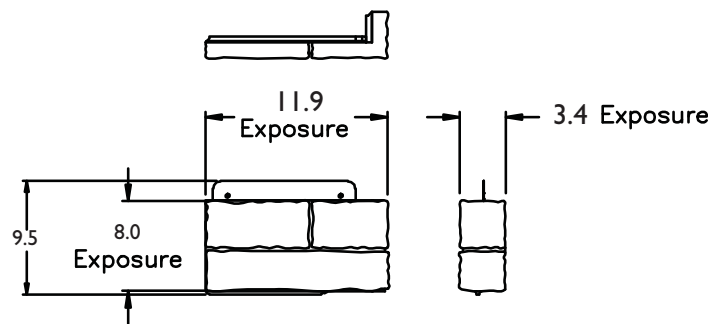
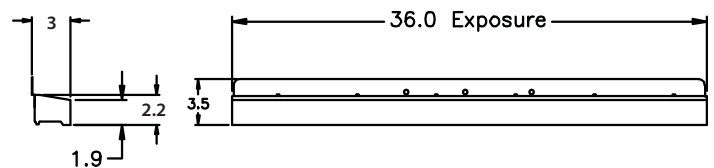

FIGURE 8 - WAINSCOT CAP



SUNDRY MATERIAL REQUIREMENTS

Water Resistive Barrier (WRB)

Minimum one layer of Grade D building paper or other WRB material meeting the requirements of ICC Acceptance Criteria #38. #15 felt provides a dark background that helps conceal any area where texture or installation allow the WRB to show. Local building code or climate may require 2 layers of WRB. It is acceptable to install felt or building paper over an existing housewrap.

Fasteners

Fasteners must be corrosion-resistant galvanized roofing nails or screws with head diameter $\frac{5}{16}$ " minimum and shank $\frac{1}{8}$ " and length suitable to penetrate framing material minimum 1". Electro-galvanized are acceptable but may exhibit premature corrosion. Owens Corning recommends the use of quality, hot-dipped galvanized nails or screws. Owens Corning is not responsible for the corrosion resistance of fastener. **Note: Treated lumber may react with metal or coating of fastener. Determine material compatibility when selecting fasteners.**

BEFORE YOU BEGIN

Inspect the area of installation to determine that framing has been done 16" on center and that the sheathing material is minimum $\frac{7}{16}$ " OSB or minimum $\frac{1}{2}$ " plywood. Verify that an appropriate water resistive barrier, flashing and caulking have been installed, or that they are part of your installation package. Check walls for plumb and square and identify any defects or protrusions. Contact the builder, registered design professional or contractor to correct any deficiencies before you proceed.

SURFACE PREPARATION

Water Resistive Barrier (WRB) Application

Cover sheathing with minimum one layer of WRB, following the installation instructions provided by the manufacturer and local building code requirements. Wrap WRB minimum 16" past all inside and outside corners. Integrate WRB with all flashing. Do not fasten bottom 12" at this time.

Wall Layout

Marking Framing Locations

Mark vertical framing locations with pencil or chalk line. It may also be helpful to mark horizontal framing locations in areas around windows, doors and wall terminations.

Determine and mark your starting point

The product must maintain a clearance from grade of a minimum 4" if soil and 2" if a hard surface such as paving or concrete. It is critical that your starting line be a level line and positioned so that appropriate clearance from grade is achieved. This location will also determine the size of partial units when you reach penetrations like windows and doors. Take time to plan a location that provides realistic unit sizes above and below windows and doors. Product dimensions have been provided to assist you with this step. See Figures 5-8.

Verify that your intended starting line provides an equal height distance to overhang, trim or cladding. Once a starting location has been determined, tack or tape WRB up and mark on sheathing. Account for starter strip nailing flange, so that bottom of starter strip lands on your desired starting location. Extend a chalk line or pencil line, across the entire surface to be covered.

Markings to Stay Level

Panels are designed to help maintain level and plumb courses but it is also advised that you mark level lines periodically up the wall as a reference. A level line every 24" is recommended. This allows you to quickly measure to the line to verify panels are still running level. Adjusting panel spacing to catch up distance or level can be done but this must be done in $\frac{1}{16}$ " or less increments.

INSTALLATION

Starter Strip

Install starter strip perfectly level at your starting point line. Fasten with roofing nails or screws every 8"-10". Fasteners should not be driven tight. Allow $\frac{1}{32}$ " gap between fastener head and strip. Additional fasteners may be added to assure strip does not easily pull away from wall at bottom edge. Lap WRB over starter strip nail flange. See Figure 4.

J Channel

Install J channel at windows, doors, material transitions, penetrations or terminations. Fasten with roofing nails or screws every 8"-10". Fasteners should not be driven tight. Allow $\frac{1}{32}$ " gap between fastener head and channel. You may need to use tape to hold screen in place until panels are installed.

Starter Strip and J Channel are subject to expansion and contraction with temperature change. Allow a $\frac{1}{4}$ " clearance at all stops or at material butt joints. Fasteners should be placed in the center of nail slots and driven straight. Do not nail tight. Maintain a $\frac{1}{32}$ " clearance (about the thickness of a dime) between the fastener head and the channel flange material. **Drill $\frac{3}{8}$ " drain holes every 12" in trim channel when used in horizontal applications.**

Installing Panels

General rules and tips of installation

- Install corners with long and short leg alternating. See Figure 9.
- Panels are installed from bottom to top.
- Panels are lapped in shingle fashion, so that tongue seats completely in groove.
- Panels should be staggered from one row to the next to avoid the alignment of vertical joints. Corners will provide stagger if used.
- Fasteners should be driven straight and flush.
- Pneumatic nails should be driven directly through nail flange. Pre-drilled holes are for hand nail or screw installation.
- Panels and corners must be installed level and plumb.
- For best appearance, pull product from multiple boxes as you work.

Owens Corning™ Versetta Stone™ panels may be hand nailed or applied with pneumatic nail gun or screw gun. Fasteners should be a minimum of 1/2" from any edge of the panel, and into framing as detailed later in these instructions.

Installing Corner Panels

Start at the bottom of the wall and position first corner, nailing flange up, into the starter channel. Level and plumb the corner and install a first fastener into the pre-drilled hole in the nailing flange closest to the 90° return. You need not drive the fastener in tight at this time as the corner **may** need to be re-positioned later. Screw fasteners work well here, as removal does not damage the nailing flange or finished stone surface, if re-positioning is required. Next, place a flat panel adjacent to the corner panel, nailing flange up and tongue into the starter channel. Now refer to the joint that is created between the corner and flat panel. Adjust both flat and corner so they are tight to the wall, level, plumb and a uniform size joint is created between the flat and corner panels. Fasten the flat panel using the instructions for flat panels below. Next, move to the adjacent wall and install a second flat against the corner using the same alignment process and fasten it. Re-evaluate your corner for best positioning and tighten your first fastener. Install a second fastener to complete the installation of the corner. Each corner will be fastened with a minimum of 2 fasteners. A minimum of 1 fastener must penetrate framing. As you progress up the wall, alternate the direction of the corner long and short leg. See Figure 9. Align each corner using this process and fastening each in the same way. It is recommended that you install corner panels with each course of flat panels and do not attempt to run up an entire corner prior to installation of flat panels

Columns

Columns and short walls will look more realistic if you make sure that the corner panels are alternated opposite on each corner. For example, start the first course with a "left hand" corner on both wall corners. See Figure 9.

Flat Panels

Starting at the bottom of the wall, position first panel, with nailing flange up, and tongue into the starter channel. Fasten panel with total of 4 fasteners in the top nailing flange. A minimum of 2 fasteners must penetrate framing, end fasteners must be located within 3" of the end of the panel. Next, position second panel into the starter channel and slide to nest end tabs with edge of the first panel. Install fasteners as you did for the first panel. Continue down the wall repeating this procedure until you reach the end. Before next course clean any debris from first course groove. A brush or small screwdriver works well for cleaning grooves. If corner panels are not being used, start next course with a half panel and install tongue into groove on top of first course. Repeat.

An automatic stagger is created by long and short leg of corner panel. Therefore, a half panel every other course is not required when corner panels are used.

FIGURE 9 - PROPER CORNER PANEL INSTALLATION

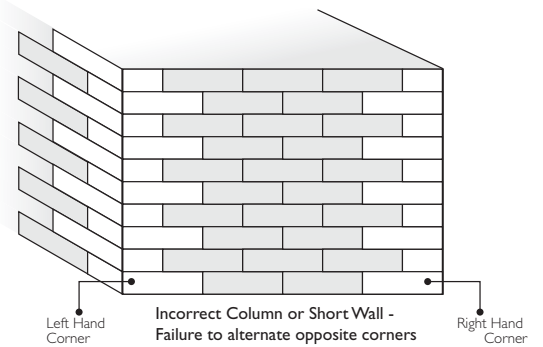
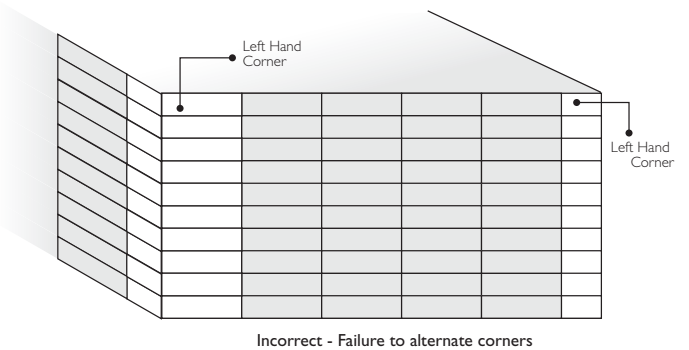
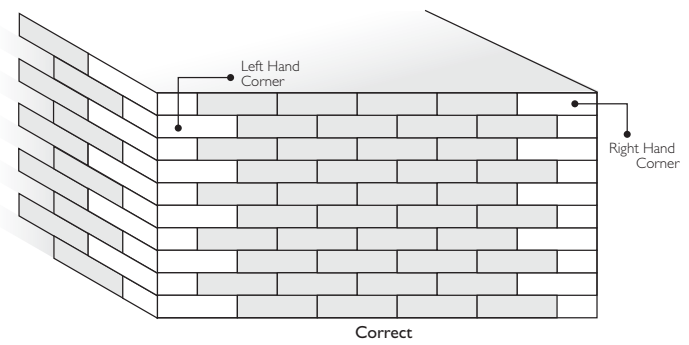

INSIDE CORNERS

Inside corners are created by alternating courses that continue into an adjoining wall. For example: first course the left wall extends into the right wall. Second course the right wall extends into the left. Due to stone texture, the water resistive barrier may be visible after installation. Using a colored flashing material inside corner, prior to installation will provide a better finished appearance. As an alternative, you can end one wall in to a trim channel and then butt next wall in to it or end both with trim channel.

TREATMENT OF OUTSIDE CORNERS OTHER THAN 90°

A corner other than 90° can be addressed by using flat panels mitered to the appropriate angle. Using a colored flashing material will help conceal WRB and provide a better finished appearance.

PARTIAL PANELS AND ACCESSORIES

Throughout the project full panels will need to be cut and modified to fit. In some cases nailing flanges will be removed. Products without nail flanges must be fastened using adhesive. Adhesive can not be expected to hold if bonded directly to water resistive barrier. In order to achieve good bond and mechanical connection to framing a material must be first nailed to framing in the area where adhesive will bond. Non-painted, clean metal flashing or expanded metal lath, fastened 16" on center into framing provides an adequate bonding surface. After bonding surface has been prepared, apply minimum $\frac{3}{8}$ " beads of adhesive, in vertical beads, every 2"-3". Install partial panel and press into adhesive to assure complete contact. It may be necessary to insert a wedge or shim between partial panel and trim to hold during curing. If the partial panel or accessory will not be retained by a Versetta Stone™ trim channel or other wood/ composite trim material, additional fasteners are required. Screws are the fastener of choice for this step. As a general rule, one additional fastener every 16" will be sufficient to supplement the adhesive. The Versetta Stone™ panel or accessory will need to be pre-drilled with a masonry drill bit of an appropriate size, as recommended by the fastener manufacturer. See "Sundry Material Requirements" section for fastener requirements. The head of this fastener will likely be visible when the installation is complete. To conceal it, we recommend a dab of colored, sanded caulk. Fasteners are easier to conceal in shaded or darker areas of the stone, but may crack a panel if installed in the simulated mortar joints. Do not over tighten fasteners. Use enough force to pull the panel into the adhesive and maintain substantial contact during curing.

INSTALLING VERSETTA STONE™ WAINSCOT CAP PRODUCT IN A WAINSCOT APPLICATION

Place the Versetta Stone™ Wainscot Cap product on top of previously installed Versetta Stone™ panel application with tongue on back of sill into groove of Versetta Stone™ flat panels below. Fasten with a minimum of 4 fasteners through the nailing flange. A minimum of 2 fasteners must penetrate framing. End fasteners must be located within 3" of the end of the nail flange. If desired, you may supplement the application with adhesive as outlined in the "Partial Panel and Accessories" section of these instructions. "L" brackets (included) are not required when using this method.

INSTALLING VERSETTA STONE™ CAP PRODUCT IN A WINDOW SILL APPLICATION

In applications where the Versetta Stone™ Wainscot Cap will be used under an existing window or opening, removal of the exposed portion of the nailing flange is necessary. Utilize a grinder with appropriate wheel or metal snips to remove the nailing flange CAUTION: this step may produce sharp edges which should be avoided. Handle with care and wear cut resistant gloves. This application also requires the use of "L" brackets (included) to support the sill. To facilitate proper fit of the bracket, a portion of the backside tongue will need to be removed in the locations the bracket will contact

the sill. Utilize hand grinder to remove the tongue in these locations. Brackets will be mounted at framing locations and should be spaced to allow 2 brackets per Versetta Stone™ Wainscot Cap. Following the application instructions for "Partial Panels and Accessories" and install metal flashing or metal lath material at location where Versetta Stone™ Wainscot Cap will be installed. Hold Versetta Stone™ Wainscot Cap under window and mark bottom location. Next mark framing locations and install "L" brackets, with screws that penetrate framing minimum one inch, at locations marked. Apply $\frac{3}{8}$ " minimum vertical beads of construction adhesive every 2-3 inches to the wall, the back of the sill or both. Vertical beads should extend onto both surfaces of the "L" bracket. Note: The "L" bracket's vertical surface is an acceptable mounting location for adhesive and can act as the mechanical connection to framing discussed in the "Partial Panel and Accessories" section of these instructions. Place Versetta Stone™ Wainscot Cap into place, level, and press firmly into adhesive. It is important to maintain full adhesive contact. Shim Cap or bend "L" brackets to achieve full adhesive contact and level status.

Additional temporary support may be needed to maintain full adhesive contact until adhesive cures.

INSTALLING VERSETTA STONE™ WAINSCOT CAP PRODUCT USING A COMBINATION METHOD.

In some applications the Versetta Stone™ Wainscot Cap product will extend beyond the jamb of a window and a combination of both methods above may be used. Hold the Versetta Stone™ Wainscot Cap under window and determine how much of it will extend beyond the window jamb. Mark and remove the appropriate portion of the nail flange as outlined in the "Installing Versetta Stone™ Wainscot Cap Product in a window sill application" section of these instructions. Following that same section, to prepare the surface with metal flashing or metal lath and "L" brackets. However, extend this treatment behind entire Versetta Stone™ Wainscot Cap mounting location. Apply adhesive as directed to the entire mounting location. Place Versetta Stone™ Wainscot Cap into place, level, and press firmly into adhesive. It is important to maintain full adhesive contact. Shim Cap or bend "L" brackets to achieve full adhesive contact and level status. Install fasteners through available nail flange as outlined in the "Installing Versetta Stone™ Wainscot Cap Product in a wainscot application" section of these instructions.

Additional temporary support may be needed to maintain full adhesive contact until adhesive cures.

INSTALLING VERSETTA STONE™ TRIM STONE

Prepare the surface as outlined in the "Partial Panel and Accessories" section of these instructions. Apply $\frac{3}{8}$ " minimum vertical beads of construction adhesive every 2"-3" to flashing/lath, back of trim stone or both. Note: It is important that the adhesive bead be large enough to create contact between stone and flashing.

Place trim stone tight to adjacent window/door/trim and press firmly into adhesive. Continue trim stone installation by attaching stone to wall, with 6 screws through pre-drilled nailing flange holes. Do not use nails for this application.

Note: If the Versetta Stone™ Trim Stone will not be retained by a Versetta Stone™ J/starter channel or other wood/ composite trim material, additional fasteners are required through the masonry portion of the panel. Screws are the fastener of choice for this step. As a general rule, one additional fastener every 16" will be sufficient to supplement the adhesive. The Versetta Stone™ Trim Stone will need to be pre-drilled with a masonry drill bit of an appropriate size, as recommended by the fastener manufacturer. See "Sundry Material Requirements" section for fastener requirements. The head of this fastener will likely be visible when the installation is complete. To conceal it, we recommend a dab of colored, sanded caulk. Fasteners are easier to conceal in shaded or darker areas of the stone, but may crack a panel if installed in the simulated mortar joints. Do not over tighten fasteners. Use enough force to pull the panel into the adhesive and maintain substantial contact during curing.

INSTALLING VERSETTA STONE™ ACCESSORIES ELECTRICAL/LIGHT ACCESSORIES

Identify electrical box connection location and verify that power has been disconnected. Prepare the surface as outlined in the "Partial Panel and Accessories" section of these installation instructions. Prior to installation of metal flashing/lath, trace enclosed electrical box extension onto the flashing or lath. Flashing material should be a minimum of 4" larger than Versetta Stone™ product being installed. Cut hole into flashing material to match outline of electrical box extension. Install flashing material over existing outlet box. Flashing/lath material fasteners should penetrate framing a minimum of 1". Fasten electrical box extension to existing electrical box keeping box level and plumb. If a telescoping electrical box extension is being used, fastened it using 1½" screws. The extension box flange should be set equal to the thickness of the Versetta Stone™ Accessories Electrical Box thickness. Weather-proof the perimeter of box penetration with additional flashing/caulk. Apply a self adhered flashing material over top edge of flashing, overlapping 1". Temporarily place light box stone over box extension making sure it is level and plumb. Trace light box stone perimeter onto flashing material. Remove light box stone and store for installation later. Install Versetta Stone™ panels, using standard installation, up and around traced electrical light box stone lines. Continue with balance of Versetta Stone™ panel installation to complete the wall. Once the wall is completed you are ready to install the light box stone. Apply ¾" vertical beads of adhesive every 2-3 inches. Adhesive beads must be thick enough to make substantial contact with back of light box stone. Install light stone box and press into adhesive to assure complete contact. Maintain pressure against electrical/light box stone to ensure proper initial bond. It may be necessary to insert a wedge or shim between box extension and light box

stone or Versetta Stone™ panels, to hold level and plum during curing. CAUTION: TEMPORARY PRESSURE OR SUPPORT MAY BE REQUIRED TO MAINTAIN FULL ADHESIVE CONTACT UNTIL CURED.

Refer to adhesive manufacturer installation instructions for temperature and cure time recommendations.

CUTTING AND MODIFICATIONS

Always follow safe tool operation instructions provided by tool manufacturer. Always wear eye protection, hearing protection and a dust mask while cutting or trimming¹. Do not cut more than one panel at a time. Straight and angle cuts can be made with any of the cutting tools outlined in the tool section of this document. Tools with a fence provide a clean and fast cut, i.e. table saw or miter saw. Trimming and staggered cuts are best made with a hand grinder utilizing a masonry blade. Holes can be made with a masonry hole saw, drill or grinder with a masonry blade. Always safely support and stabilize the panel during modification.

CLEANING

Cutting dust and general construction dust can be removed with clean water and a nylon bristle brush. Stubborn dirt may require the addition of a granulated general detergent. **Do not clean with harsh chemicals or acid products.**

SALT AND DE-ICING CHEMICALS

All concrete and masonry materials are vulnerable to damage by salt and de-icing chemicals. Do not use salt or de-icing chemicals on the product or in areas adjacent that may splash onto it. See printed warranty for more details.

GOOD BUILDING PRACTICES

Make sure the product is being applied to a wall or structure that meets all building code requirements. Code approved flashing materials must be present at all terminations, penetrations and material transitions. Control water and minimize penetration caused by roof run off, gutters and downspouts. If there is any question as to the integrity of the wall or water management principles, contact the appropriate owner, registered design professional or builder for corrective measures.

REPAIR/REMOVE/REPLACE

Using a masonry saw or grinder with a diamond blade and proper personal protective equipment, cut out the area to be replaced. Take care to avoid damaging the weather resistant barrier behind the panel. Trim new panels to fit the area you just cut out. Repair any damage to the water resistive barrier, making sure to lap and seal in shingle fashion. Follow the partial panel installation method to install replacement panel.

*Versetta Stone™ Technology Patent Pending

I. **CAUTION:** Contains Crystalline Silica. Dusts from cutting or sawing may create possible cancer hazard. Dusts of this product may cause irritation of the nose, throat and respiratory tract. Avoid prolonged or repeated inhalation of dusts from this product.

A properly fitted NIOSH approved N-95 series disposable particulate filtering face piece respirator (formerly referred to as "dust masks") should be used when mechanically altering this product (e.g., sawing, cutting, drilling or similar dust generating processes). Wear long-sleeved shirt, long pants, gloves and safety glasses with side shields when handling and installing material. Wash hands and face with soap and warm water immediately after handling this product.



Versetta Stone™

The beauty of stone, perfect by design.™

OWENS CORNING MASONRY PRODUCTS, LLC
Pub. No. 10012480. Printed in U.S.A. April 2010.
©2010 Owens Corning.